

EN



User manual

with instructions for installation

of AUTOTERM liquid heaters

30SP-24 35SP-24

Manufacturer: LLC ADVERS

Russia, 443068, Samara, ul Novo-Sadovaya 106

www.autoterm.ru

Manufacturer's representative office: LLC AUTOTERM

Paleju iela 72, Mārupe, Mārupe Municipality, LV-2167, Latvia

Warranty Department warranty@autoterm.com

Technical support service@autoterm.com

www.autoterm.com

Table of Contents

| | | |
|----|---|----|
| 1 | Purpose | 3 |
| 2 | Main parameters and characteristics | 3 |
| 3 | Safety measures | 4 |
| 4 | Heater design and operation description | 5 |
| 5 | Heater control unit (CU) | 6 |
| 6 | Heater control button | 9 |
| 7 | Faults | 9 |
| 8 | Faults of heater control system elements | 9 |
| 9 | Maintenance | 12 |
| 10 | Main requirements to installation of heater and its units | 12 |
| 11 | Recommendations | 14 |
| 12 | Transportation and storage | 14 |

Warning!!

1. Never operate heater with frozen coolant.
2. Never disconnect power supply to heater while heater is operated.
3. Regularly control battery charge level.
4. It is recommended to disconnect heater from power source (battery) during long idle standing or storage of vehicle, in order to prevent discharging (heater current consumption when not operating (30 ÷ 40) mA).

1 Purpose

This user manual (hereinafter referred to as UM) is intended for study of design, operation and regulations of operation of starting diesel heaters 30SP-24 и 35SP-24 (hereinafter referred to as heater) intended for starting heating of diesel engine with liquid cooling system and heating of passenger cabin at ambient temperature down to -45°C.

Full properties of heater include the following functions:

1. Provision of safe engine heating at low ambient temperature;
2. Additional engine heating and cabin heating with operating engine at very low temperature;
3. Independent pump operation with not operating heater.

Manual may not reflect insignificant design changes made by the manufacturer after approving this UM.

2 Main parameters and characteristics

Main technical; characteristics of heater are given with $\pm 10\%$ tolerance obtained at nominal supply voltage and 20° C temperature.

| | 30SP-24 | 35SP-24 |
|--|--|---------|
| Heat productivity, kW | 30 | 35 |
| Fuel consumption, L/h | 3.9 | 4.3 |
| Nominal supply voltage, V | 24 | |
| Operating supply voltage, V | 20.5 ... 30 | |
| Used fuel | diesel fuel according to GOST 305 or GOST 52368 depending on ambient temperature | |
| Heat carrier | tosol, antifreeze | |
| Heater consumed power at the set mode without electric pump consumption, W | 80 | 120 |
| Electric pump maximum consumed power, W, max | 108 | |
| Heater switching on/off | manual | |
| Heater weight with all elements, kg, max | 20 | |

3 Safety measures

- 3.1. Heater installation, due to its complexity, must be carried out by specialized organizations. Heater contains combustion chamber (where fuel and air mixture combusts), heat exchanger (ensuring heat transfer to coolant), electric motor with pump, gear fuel pump, blower, control unit (controlling heater operation according to program), temperature sensors.
- 3.2. Heater may only be used for purposes specified in this user manual.
- 3.3. Never install heaters on special vehicles intended for transportation of dangerous freights.
- 3.4. Never lay fuel line inside vehicle cabin.
- 3.5. Heater-equipped vehicle must have a fire extinguisher.
- 3.6. Never use heater in places, where combustible fumes and gases or large amounts of dust may accumulate.
- 3.7. Never operate heater in closed non-ventilated premises.
- 3.8. Heater must be switched off when refuelling the vehicle.
- 3.9. In case of faulty operation of heater contact the specialized repair organizations authorized by the manufacturer.
- 3.10. Disconnect heater from battery when carrying out vehicle electric welding works or heater repair works.
- 3.11. Never operate heater with frozen coolant.
- 3.12. Observe safety measures specified in regulations for carrying out works with vehicle electric network, fuel and liquid system during heater installation and removal.
- 3.13. Never connect heater to vehicle electric network and switch heater on if engine is operating and battery is absent.
- 3.14. Never disconnect power supply to heater until blowing cycle is completed.**
- 3.15. Never connect or disconnect heater connectors if heater power supply is on.**
- 3.16. After switching heater off, switch it back on at least after 5-10 seconds.
- 3.17. If the mentioned requirements are not observed, consumer has no rights to heater warranty service.
- 3.18. For the purpose of safe operation of heater, it is necessary to contact the service centre after three consecutive unsuccessful starts, in order to ascertain and eliminate the fault.

4 Heater design and operation description

Heater operates independently of vehicle engine.

Heater fuel and electric power supply is realized from vehicle. Heater electric connection layout is shown in Fig. 1.

Heater (main heater units shown in Fig. 2) is an autonomous heating device containing:

- heater;
- electric motor with pump for forced circulation of vehicle cooling system coolant (tosol) through heater heat exchanging system;
- control unit (included with heater) controlling the mentioned devices;
- bunched wires for connecting heater elements and connecting heater to vehicle electric network

Heater operation principle is based on heating liquid in engine cooling system that is forcedly circulated through heater heat exchanging system.

Combustion chamber fuel and air mixture combustion gases are used as a source of heat for heating the liquid. Heat through heater heat exchanger walls is transferred to coolant circulated through vehicle engine cooling system.

Test and control of capacity of heater elements is carried out during switching on of heater. Then electric pump is switched on.

If in working order and with liquid temperature under $+5^{\circ}\text{C}$, TEH is switched on for heating fuel nozzle (switched off after liquid temperature reaches $+8^{\circ}$), electric motor operating the fan for supplying air into combustion chamber and gear fuel pump is switched on. After several seconds, a spark is supplied, electromagnetic valve opens and fuel is supplied. Fuel and air mixture forms in combustion chamber. Fuel and air mixture is ignited by high voltage ignition spark. Fuel mixture combustion in combustion chamber is controlled by flame indicator. All processes during heater operation are controlled by control unit. If liquid temperature is under $+5^{\circ}$, ignition is postponed by one minute.

If liquid temperature is above 82°C , heater goes into “cooling” mode, combustion process is stopped, pump continues operating to ensure liquid circulation in vehicle cabin heating system. If liquid temperature is under 72°C , heater automatically restores operation.

Heater operates until switching-off command is given. Blow cycle – 150 seconds.

If heater is manually or automatically switched off due to a fault, fuel supply is stopped and combustion chamber is purged with air.

Peculiarities of automatic control of heater operation in emergency and in case of incidents:

1) if heater has failed to start for any reason, starting process is automatically repeated. Heater is switched off after two unsuccessful attempts;

2) if combustion stops during heater operation, heater attempts another ignition attempt;

3) in case of heater overheating (e. g., coolant circulation fault, air plug, etc.) heater is automatically switched off;

4) if voltage falls under 20.5 V or rises above 30 V, heater is switched off;

5) in case of emergency switch-off of heater, LED is blinking on the dashboard. Number of blinks corresponds to the type of fault. See deciphering of the type of fault in Section 8 of this manual.

5 Heater control unit (CU)

CU ensures control of heater.

CU performs the following functions:

- a) switches heater on/off by command;
- b) initial diagnostics (fault check) of heater units during starting;
- c) diagnostics of heater units throughout operation;
- d) starting and automatic operation depending on coolant temperature at heater output;
- e) heater switch-off:
 - if one of controlled units loses performance;
 - if parameters are outside of allowed limits (coolant temperature, voltage);
 - flameout in combustion chamber;
 - switch-off command is given.

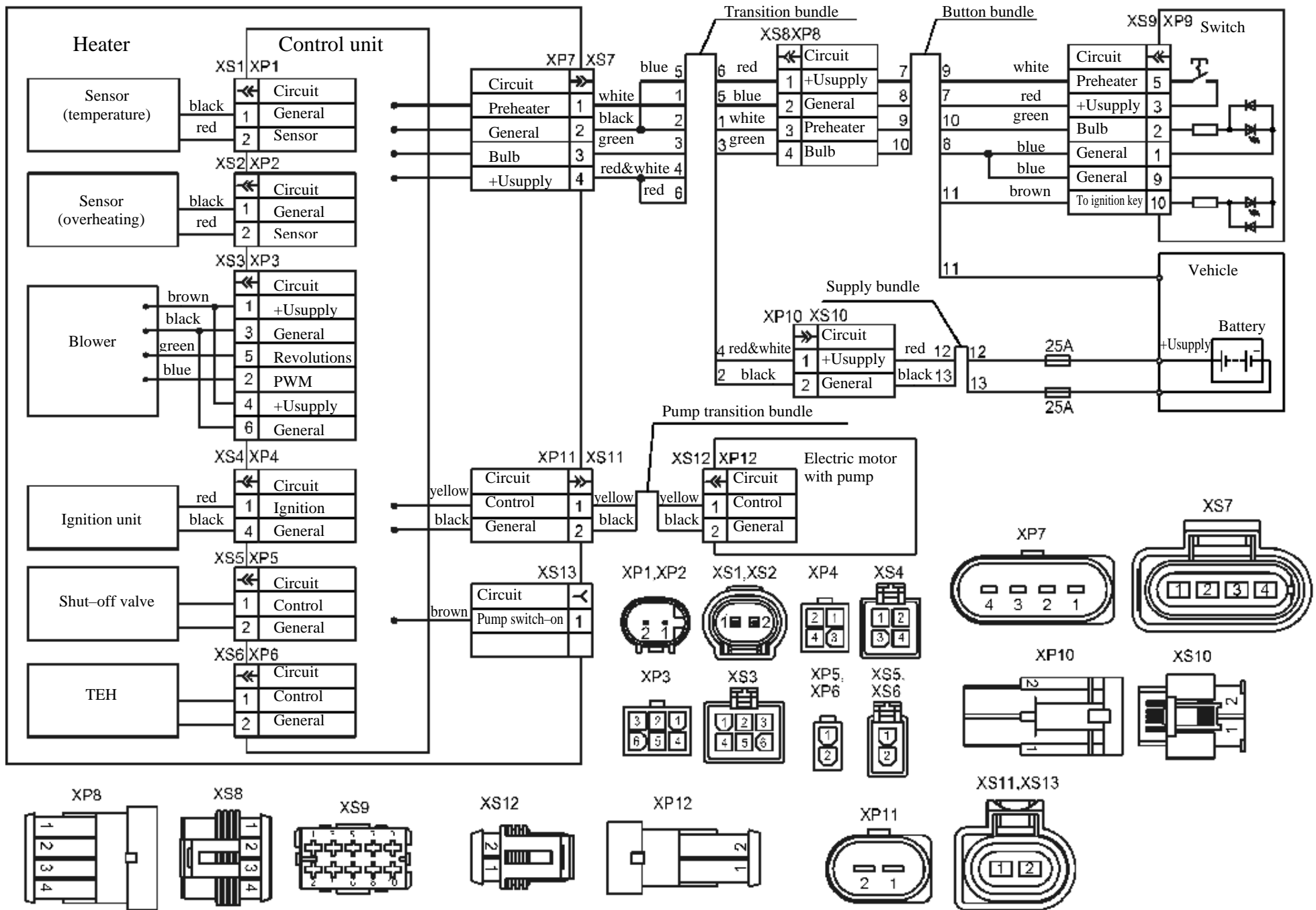

Fig. 1 – Electric connection layout

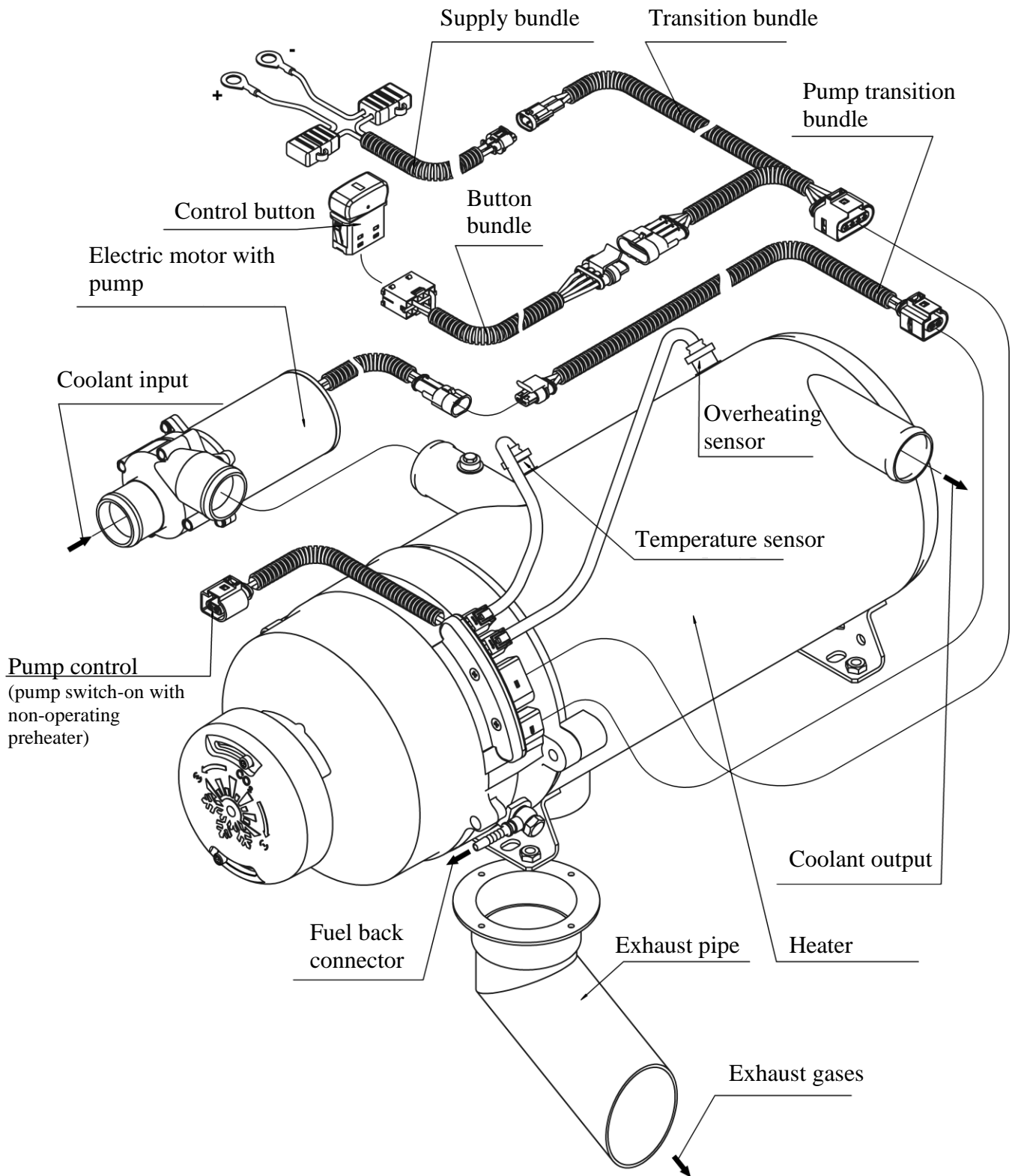

Fig. 2 – Heater main unit connection layout

6 Heater control button

Two buttons and LED indicator are on bus dashboard. One button starts and stops heater. Another button switches pump on/off if heater is not operated.

LED indicator shows heater status:

- lit – if heater operates;
- blinks – in case of fault (emergency). Number of blinks corresponds to the type of fault (see Table 1);
- not lit – if heater is not operating.

Attention:

To switch heater again on after automatic stop, release and press switch-on button again at least after 5-10 seconds.

7 Faults

7.1 Faults that can be eliminated independently. Heater does not start after switching on; it is necessary to:

- 1 Check fuel in tank;
- 2 Check voltage on XS7 connector (see electric connection layout in Fig. 1). If no voltage on XS7 connector, it is necessary check and, if necessary, replace 25 A fuses on power supply bundle.

7.2 Heater faults are automatically shown by LED blinking on dashboard.

7.3 See typical heater faults and elimination methods in Section 8.

7.4 In case of faults not described in Clause 7.1, contact the service centre.

8 Faults of heater control system elements

8.1 Start search for faults with checking connector contacts of checked circuits (see electric connection layout in Fig. 1).

8.2 Control unit is faulty and must be replaced, if dashboard LED is lit after supplying voltage to heater with heater switched off.

8.3 All other heater faults are shown in Table 1.

Table 1

| Number of blinks | Fault description | Comment. Fault elimination |
|------------------|---|--|
| 1 | Overheating | Overheating sensor or temperature sensor shows temperature above 102°C. Fully check circulation pump liquid circuit and operation. |
| | Possible overheating detected | Difference of temperatures measured by overheating sensor and temperature sensor is too big. Check overheating sensor and temperature sensor, replace, if necessary. Check circulation pump operation. |
| 2 | Starting attempts exhausted. Ignition did not happen (twice). | No fuel, valve does not trigger. Check combustion air supply system and gas-escape line. No spark, control unit fault. |
| 3 | Flameout | Not sufficient fuel or combustion air. Heat exchanger clogged up. Exhaust pipe clogged up. |
| 4 | Ignition unit fault. | Short circuit, interruption. |
| | Air blower fault – tight rotation. | Increased friction in bearings or fan touching. |
| | Air blower motor overload | Fan touching, tight rotation due to bearings, etc. |
| | Air blower fault – motor is not rotating | Contact oxidation in terminal block. Jamming due to bearing or rotor destruction. Foreign objects, etc. |
| 5 | Flame indicator fault – flame before ignition | Control unit fault |
| | Flame indicator fault – flame during blowing. | Control unit fault Valve does not close. |
| 6 | Overheating sensor fault. | Short circuit, interruption, control unit fault. |
| | Temperature sensor fault. | Short circuit, interruption, control unit fault. |

Table 1 continued

| Number of blinks | Fault description | Comment. Fault elimination |
|------------------|--|---|
| 7 | Electric motor with pump fault | Remove air from vehicle liquid circuit, following vehicle manufacturer's instructions. Check circulation pump electric wires for short circuit, check pump part for contamination, replace, if necessary. |
| | Electromagnetic valve fault. | Short circuit, interruption, control unit fault. |
| 8 | Nozzle heater fault (TEH) | Short circuit, interruption, control unit fault. |
| 9 | Switching-off, increased voltage | Check battery, voltage regulator and leading-in wiring. Voltage must not be above 30 V. |
| | Switching-off, decreased voltage | Check battery, voltage regulator and leading-in wiring. Voltage must not be below 20.5 V. |
| 10 | Control unit blocked* | Allowed ignition attempts exhausted. To unblock, switch heater on and within 20 seconds remove supply voltage, then after 5 seconds supply the voltage. Repeat the procedure two more times |
| 11 | Control unit built-in temperature sensor fault | Replace control unit |

* to unblock, after switching heater on within 20 seconds remove XS7 connector from heater and after 5 seconds connect XS7 connector back (according to electric connection layout, Fig. 1). This procedure must be repeated three times.

9 Maintenance

Heater maintenance includes the following types:

- regular maintenance;
- seasonal maintenance (when putting vehicle in winter operation).

Regular heater maintenance must be carried out during heating season or for prevention (in warm period of the year). List of works is shown in Table 2.

Seasonal maintenance is carried out before heating season. For seasonal heater maintenance, check its technical condition according to Table 2.

Table 2

| Name of maintenance object, Content of works and methodology | Technical requirements to object | Devices, materials, tools | Maintenance type | |
|---|----------------------------------|--|------------------|----------|
| | | | Regular | Seasonal |
| Electric equipment Check security of attachment of electric contacts in heater devices. Remove dirt or oil film on contacts using clean suede and white spirit. Remove burning film on working surface of contacts using fine glass paper No. 150 GOST6456-82 and wipe with white spirit. | Visual inspection | White spirit | Every 1000 h | + |
| Heat exchanger Check for signs of leakage Tighten clamp connections, if necessary. | Visual inspection | Screwdriver | Every 500 h | + |
| Fuel system Check fuel line tightness, tighten clamp connections, if necessary. | Visual inspection | Screwdriver | Every 500 h | + |
| Burner Check air intake opening for absence of clogging. Check for signs of leakage Clean flame indicator inspection window. Check ignition unit electrodes. | Visual inspection | Wrench S=13 Clean rags White spirit | Every 1000 h | + |
| Exhaust system Check exhaust line for absence of clogging and clean it. Remove flue tube from heat exchanger and check it for damages of contamination | Visual inspection | Wrench S=13 Clean rags White spirit | Every 1000 h | + |

10 Main requirements to installation of heater and its units

When installing heater on vehicle, be sure to observe the requirements specified below.

10.1. General instructions for heater installation.

10.1.1. Electric pump and heater should be installed below vehicle radiator expansion tank level. Pump operating position – from horizontal to vertical with pump downwards.

10.1.2. After installation of heater or performing any works in cooling system (repair or liquid change), remove air plugs from the whole liquid cooling system and heater. All pipeline connection places must be airtight.

10.1.3. Fuel and liquid pipelines must be installed, taking into account impermissibility of their contact with vehicle's hot and vibrating elements.

10.1.4. To speed up warming-up, engine can be started with heater operating. If battery voltage is decreased, program allows starting engine with product operating with short-term (up to 15 seconds) voltage decrease to 18 V.

10.1.5 Carry out all heater maintenance works with disconnected XS7 connector.

10.1.6. Never position air intake opening against incoming air flow during vehicle travel.

10.1.7. Never position exhaust pipe outflow opening against incoming air flow during vehicle travel.

10.2. *Installation of pressure and return fuel pipeline*

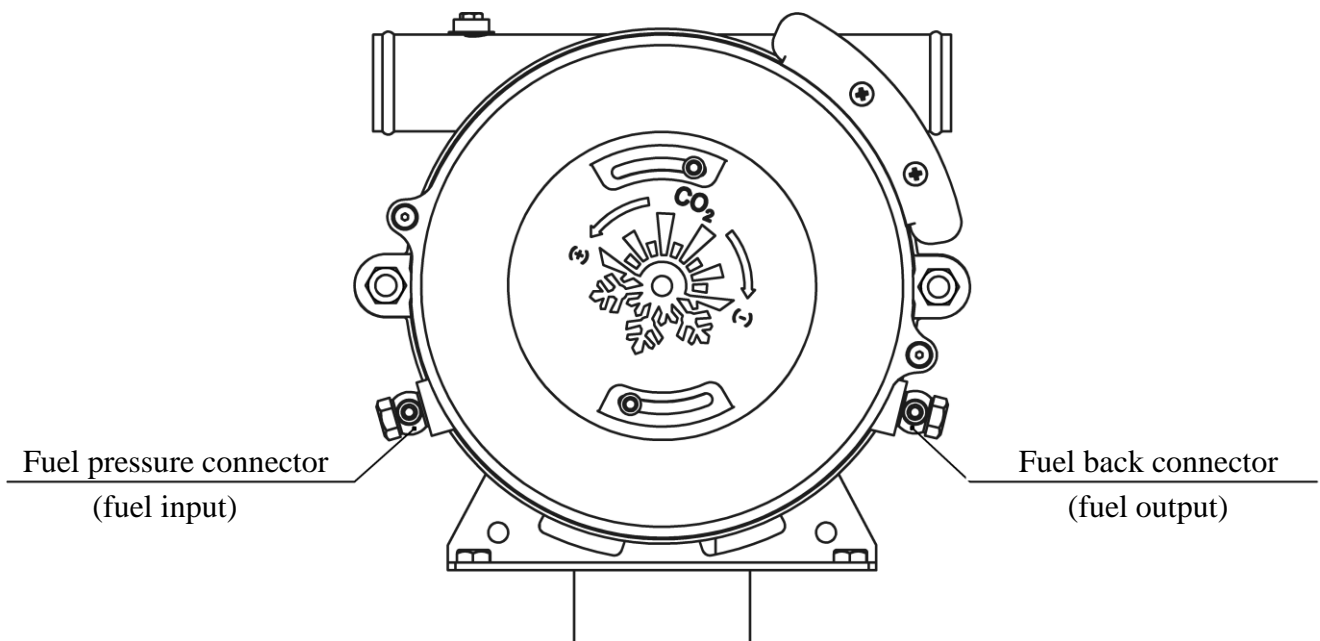

Fig. 3. Connection of pressure and return fuel pipeline

Fuel pipeline must be securely fastened and protected from mechanical impact.

11 Recommendations

11.1 To ensure safe operation of heater, it is necessary to switch it on at least monthly for 5-10 minutes, including during warm period of the year, if heater is not operated. This operation is necessary to remove viscous films on moving parts of fuel pump and nozzle. Failure to carry out this operation may cause heater fault.

12.2 Safe operation of heater depends on type of fuel that must be used depending on ambient temperature.

11.3 It is recommended to disconnect heater from power source (battery) during long standing or storage of vehicle, in order to prevent discharging (heater current consumption when not operating (30 ÷ 40) mA).

12 Transportation and storage

12.1 Heaters are safe during transportation and may be transported by any vehicles, including by air and railway, ensuring protection of packed products against precipitation and climatic factors according to condition 5 of GOST15150-69, and from mechanical impact according to category C of GOST 23216-78.

12.2 Conditions for storing heaters in the manufacturer's package in the part of climatic factors must correspond to storage condition 2 of GOST 15150-69.

12.3 Storage period of heaters in the manufacturer's package – 24 months.

In case of technical problems please contact the dealer or nearest service centre. List and map of nearest certified service centres can be found at the website: www.autoterm.com/partners.